

Gleisbelegtmeldung über Kontaktgleise (Standard) mit HSI-88-USB / Patch-Kabel nach s88-N Track occupancy feedback via contact tracks (standard) with HSI-88-USB / patch-cable to s88-N

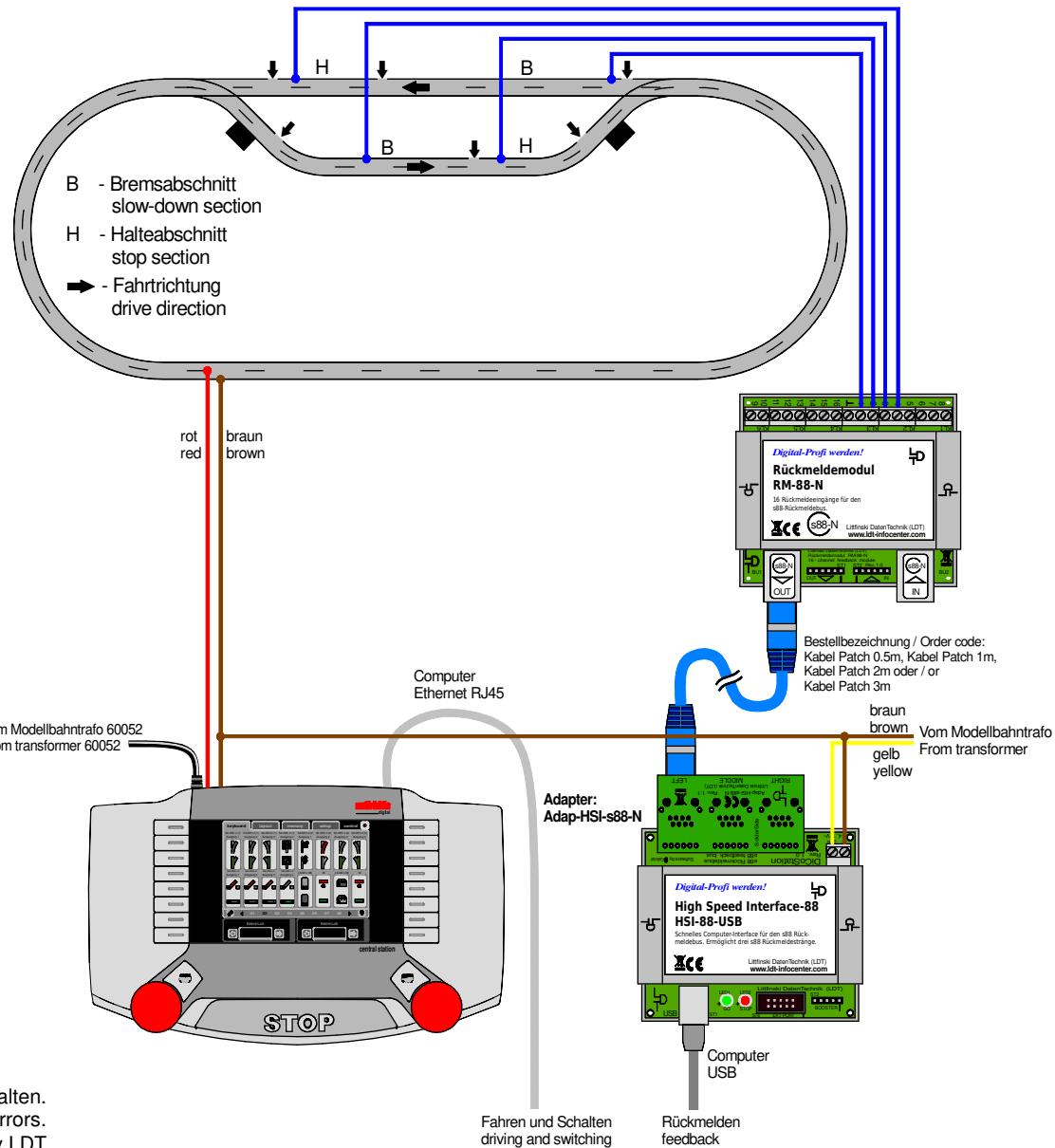

Technische Änderungen und Irrtum vorbehalten.
 Subject to technical changes and errors.
 © 07/2020 by LDT

