

16-fold Feedback Module

for the s88-feedback bus
from the *Digital-Professional-Series!*

RM-88-N O-F Part-No.: 310102

>> finished module <<

- ⇒ with **16 opto-coupling input connections**
(for potential separation and for high interference protection e.g. contact tracks [one isolated rail], switch tracks or reed-contacts or turnout feedback reports).
- ⇒ for **s88-standard connections and s88-N**
(with 6-poles s88-pinbars as well as RJ-45 sockets and suitable for 5 and 12V bus voltage).
- ⇒ **suitable for the digital control:**
Märklin-Digital~/=, CS 1, 2, 3 plus and L88, Intellibox, TWIN-CENTER, HIS-88(-USB), EasyControl, ECoS, DiCoStation.

This product is not a toy! Not suitable for children under 14 years of age! The kit contains small parts, which should be kept away from children under 3 years of age! Improper use will imply danger of injuring due to sharp edges and tips! Please store this instruction carefully.



CE Part-No.:
24 80 34



Introduction / Safety Information:

You have purchased the feedback module **RM-88-N-O** for your digital model railway.

The **RM-88-N-O** is a high quality product, which is supplied within the *Digital-Professional-Series* of Littfinski DatenTechnik (LDT).

We are wishing you having a good time using this product.

The finished modules come with **24 month warranty**.

- Please read the following instructions carefully. Warranty will expire due to damages caused by disregarding the operating instructions. LDT will also not be liable for any consequential damage caused by improper use or installation.
- **Attention:** Please switch-off your digital control unit and unplug all transformers from AC-current before starting any installation.

General functions:

The feedback module **RM-88-N-O** contains 16 inputs and is compatible to the Märklin feedback module s88. The module contains additionally **opto-coupling inputs** and is therefore extremely interference protected. This makes it as well possible to connect without problems **potential bounded contacts**, such as two-rails-two conductor model railway systems.

Connecting the RM-88-N-O to command stations or interfaces:

Reports of up to **31** feedback modules **RM-88-N-O** can be evaluated by a Märklin **INTERFACE, Central Station 1, 2 and 3 plus, Intellibox, TWIN-CENTER, EasyControl, ECoS, HSI-88-(USB) and DiCoStation**.

On each Märklin **Memory** can be up to 3 feedback modules **RM-88-N-O** connected.

The Märklin **Module Link L88 (60883)** provides the operation of **31 RM-88-N-O** per bus line.

All feedback modules will receive the **operating current from the s88-feedback bus**. This will apply for **s88-standard feedback module** and for the feedback module **RM-88-N-O**.

If you want to extend your layout with **RM-88-N-O** feedback module you can combine those with our feedback module **RM-DEC-88(-Opto), RM-88-N, RM-GB-8(-N)** respectively with s88 feedback module of other manufacturers.

The **addresses** of the **feedback module** are related to the **sequence** of the **connection** to the **command station** respectively to the **interface**. The **feedback module**, which is directly connected to the central unit, will receive always the **address 1**. Further details can be found within the **operation instruction** of your **command station** respectively your **interface**.

The feedback module **RM-88-N-O** contain **two 6-poles pin-bars** for the **s88-standard connection** and as well two

RJ-45 sockets for a bus connection according to . At the **RM-88-N-O** are **pin-bars** and **sockets marked with OUT and IN**.

Out indicates the **connection in direction to the command station or interface**. **IN** indicates the **connection to the next following feedback module** within the **s88-bus line**.

Command stations and **interfaces** are always equipped with an **s88-input** for an **s88-standard connection**.

For the **s88-standard connection** is an **interference protected twisted s88-bus cable** with **original s88-bus plugs** available.

The **plugs** of the **s88-bus cable** are **correct attached** onto the **6-poles pin-bar** of the **RM-88-N-O** if the **white single wire corresponds** with the **white marking** on the pc-board **next to the pin-bar**.

The direction of the **cable has to be directly away from the feedback module**. **Additionally attend** to the position of the **plugs** on the **6-poles pin-bars**. **No offset will be acceptable**.

For the  s88-bus connection we offer a **screened blue patch-cable** with **RJ-45 plugs**.

Attention: **Command stations** with **PC-network connection** (e.g. **Central Station 1, 2 and 3 plus** and **ECoS**) contain as well a **RJ-45 socket**. **It is not acceptable to connect the RM-88-N-O to the RJ-45 network sockets**.

Connection of contacts:

1. Three-conductor rail-system

Switch rails, contact rails and **reed-contacts** can be connected to the input clamps 1 to 16 of the feedback module **RM-88-N-O** as shown below.

Kontaktart Type of contact

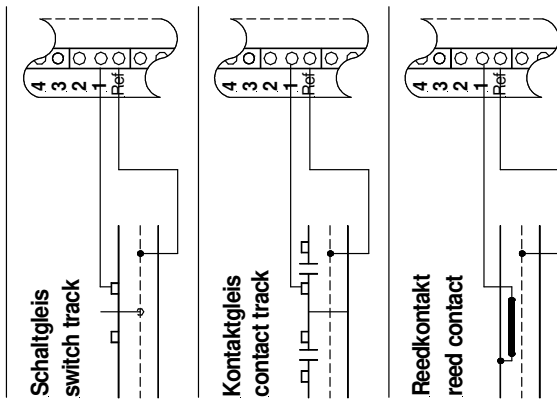

All shown above connections conform exactly to the known wiring of the s88.

There will be a small difference:

For transmitting an occupancy report is a small current flow required at the opto-coupling inputs of the feedback module **RM-88-N-O**. For this purpose shall be the **reference input (middle connection clamp marked with Ref)** connected to the digital current pole of the supply to the **middle conductor**.

At the **tree-conductor system** is this the pole with the cable color "red". From which booster this pole will be gathered does no matter as long as all boosters have a common connection to the system ground (brown).

Further sample connections can be found at the Internet on our Web Site (www.ldt-infocenter.com) at the section "Downloads" and "Sample Connections". Beside the single sample connections we recommend the file "RM-88_Info" within the section "Downloads".

The **16 opto-coupling inputs** of the feedback module **RM-88-N-O** have a high interference immunity.

Nevertheless if there will be any interferences is the reason most that the connection cables to the contacts are very long and installed very narrow. It can even come to some signal transfer between two wires. Although only one section is actually occupied several sections can be reported to be occupied.

The described problem can be solved by using interference **suppression diodes** or **decoupling diodes** within the connection wire to the reference input. A wiring sample can be found on our Web Site at the section "Sample Connections".

2. Two-conductor rail-system:

If you use **reed contacts** or other **potential-free contacts** for feedback signals on your layout you can install the wiring to the feedback module **RM-88-N-O** as shown at the below circuit.

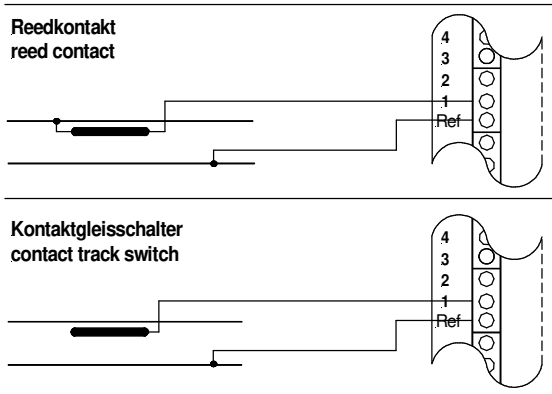

Model-railroader, using the Märklin-Digital= or Arnold-Digital-System had in the past not the possibility to use the usual **contact-rail switches (e.g. Arnold 7440)** for the feedback report.

The **RM-88-N-O** contain opto-couplings at the input for the required potential separation.

This makes the direct connection of **contact-rail switches** and **non-potential-free track occupancy monitors** possible (see the lower draft).

The above sample indicates that the **Ref-clamp** of the feedback module **RM-88-N-O** has been connected to a pole (lower rail) of the digital current.

The metallic wheel of a passing locomotive or railroad carriage will produce via the contact-rail-switch an electrical connection to the second pole (upper rail) of the digital current.

Even the **shortest switch impulses** will be transferred by the feedback module **RM-88-N-O** because they will be **stored** via the **s88-feedback bus** until the digital control unit or the interface will request this information.

Feedback module from our **Digital-Professional-Series** are easy to use on your digital model railroad, as they **are 100% compatible** with the s88 feedback bus.

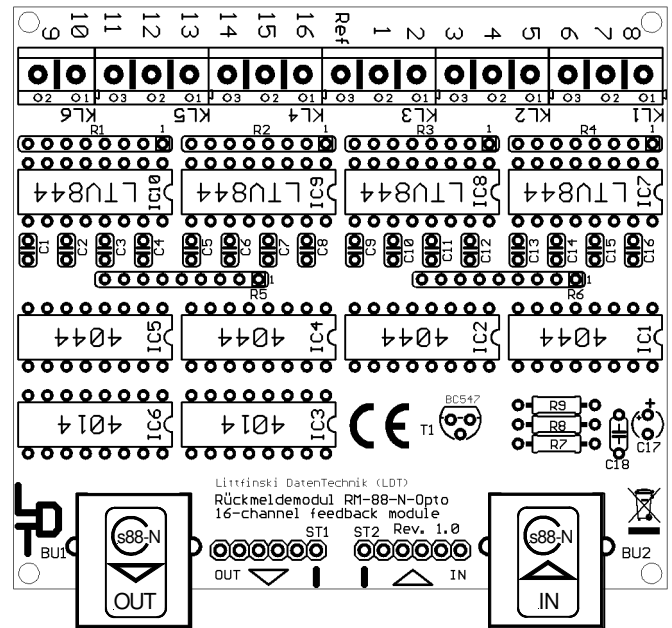

Accessories:

For safe **installation** of the feedback modules below your model layout we offer an **installation set** under the order code **MON-SET** and for the assembled kits a sturdy exact matching **case** (order code: **LDT-01**).

Further products from our **Digital-Professional-Series**:

RM-GB-8

8-fold feedback module with integrated occupancy detectors for the s88 feedback bus.

S-DEC-4

4-fold turnout decoder for 4 magnet accessories with free programmable decoder addresses and possible external power supply.

Made in Europe by
Littfinski DatenTechnik (LDT)
 Bühler electronic GmbH
 Ulmenstraße 43
 15370 Fredersdorf / Germany
 Phone: +49 (0) 33439 / 867-0
 Internet: www.ldt-infocenter.com

Subject to technical changes and errors. © 06/2019 by LDT
 Märklin and Arnold are registered trademarks.