



4-fold turnout decoder

with possible external power supply

from the *Digital-Professional-Series* !

S-DEC-4-DC-G Part-No.: 910213

>> finished module in a case <<

Compatible to the DCC-Format:

(e.g. Lenz Digital Plus, Arnold-, Märklin-Digital=, Intellibox, TWIN-CENTER, Roco-Digital, EasyControl, ECoS, KeyCom-DC, Digitrax, DiCoStation, Zimo and others)
(switching of turnouts via Lokmaus 2® and R3® is possible)

For digital control of:

- ⇒ up to 4 twin-coil magnet accessories (e.g. turnouts or semaphore-signals).
- ⇒ up to 8 single-coil magnet accessories (e.g. uncoupling tracks).
- ⇒ up to 4 permanent power switch units [DSU] (e.g. illumination).

This product is not a toy! Not suitable for children under 14 years of age!
The kit contains small parts, which should be kept away from children under 3!
Improper use will imply danger of injuring due to sharp edges and tips! Please store this instruction carefully.



Introduction/Safety instruction:

You have purchased the 4-fold turnout decoder **S-DEC-4-DC** for your model railway supplied within the assortment of Littfinski DatenTechnik (LDT).

We are wishing you having a good time using this product.

The **S-DEC-4-DC** is suitable for the **DCC Data format**, as used for instance at the systems of **Lenz-Digital Plus, Arnold-, Märklin-Digital=, Intellibox, TWIN-CENTER, Roco-Digital, EasyControl, ECoS, KeyCom-DC, Digitrax, DiCoStation and Zimo.**

The decoder **S-DEC-4-DC** can not only switch turnouts via the **turnout addresses** but also responds to **loc-addresses**. Therefore is it possible to shift turnouts with the keys **F1** to **F4** of the **Lokmaus 2®** or **R3®**.

The decoder **S-DEC-4-DC** is **multi digital** and can be installed to the **Intellibox** and on **TWIN-CENTER** without any problems.

The decoder comes with **24 month warranty**.

- Please read the following instructions carefully. Warranty will expire due to damages caused by disregarding the operating instructions. LDT will also be not liable for any consequential damages caused by improper use or installation.

Connecting the decoder to your digital model railway system:

- **Attention:** Before starting the installation switch off the drive voltage by pushing the stop button from the command station or disconnect the main supply to all transformers.

The decoder receives the **digital information** via the clamp **KL1**. Connect the clamp directly to the command station or to a booster assuring the supply of digital information free from any interference.

The DCC-Digital-Systems uses different color codes respectively indications for the two digital cables. Those markings are indicated next to the clamp **KL1**. These markings have not necessarily to be maintained correct as the decoder converts the signal automatically to be correct.

The decoder receives the **power supply** via clamp **KL2** (middle and left clamp marked with ~). Voltage in the range of 12 to 18V~ is acceptable (alternate current output of a model railway transformer).

If you **do not** want to supply power to the decoder **S-DEC-4-DC** from an **external transformer** you can **connect the clamp KL1 to KL2** with two wires. In this case the decoder will get the power supply **complete** from the **digital system**.

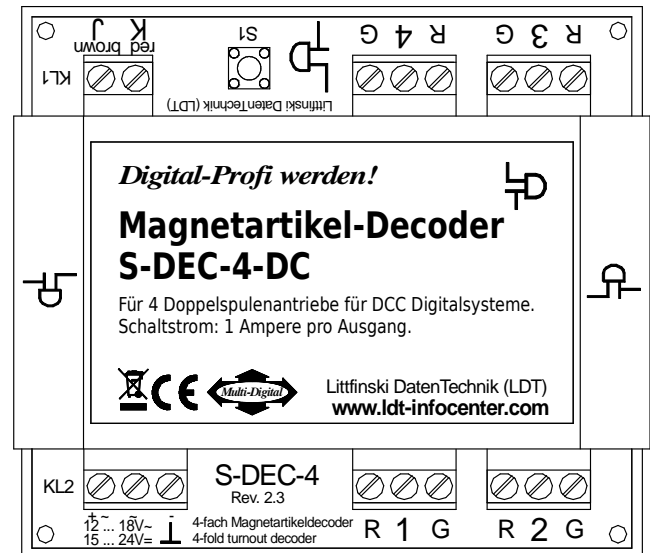

Now connect turnouts, signals, uncoupling tracks or the permanent power switch units [DSU] to the 3-pole clamp marked 1 to 4.

The common conductor of a double coil (turnout or semaphore signal) has always to be connected to the middle clamp of the relevant decoder output. The two remaining cables mostly marked with red (turnout round) and green (turnout straight) shall be connected to the clamps marked ,R' and ,G' accordingly.

Programming the decoder addresses:

To program the decoder address a turnout has to be connected to the output 1 of the decoder.

- Switch on the power supply of your model rail way.
- Adjust the **speed** of all connected speed controller to **zero**.
- Press the programming key S1.
- The turnout connected to output 1 will move now automatically every 1.5 seconds. This indicates that the decoder is in the programming mode.
- Switch now one turnout of the **group of four** assigned to the decoder via the keyboard of the control unit or via a remote control. For programming the decoder address you can also release a turnout switch signal via a personal computer.
Remarks: The decoder addresses for magnetic accessories are combined into **groups of four**. The address 1 to 4 build the first group. The address 5 to 8 build the second group etc. Each **S-DEC-4-DC** decoder can be assigned to any of these groups. Which turnout of a group will be activated for the addressing does not matter.
- If the decoder has recognized the assignment correctly the connected turnout will move a little faster. Afterwards the movement slows down to the initial 1.5 seconds again.

- Leave the programming mode by pressing the programming key S1 again. The decoder address is now permanently stored but it can be changed at any time by repeating the programming as described above.
- If you press the first key of the programmed group of keys or you send a switch signal for this turnout from a PC the addressed turnout should move into the called direction either into round or into straight. In case the movement goes the wrong way please exchange the two turnout connection cables at the ,G'reen (straight) and ,R'ed (round) marked connection clamps of the decoder output 1.

Switching turnouts via loc-addresses (e.g. Lokmaus 2® or R3®):

The decoder **S-DEC-4-DC** makes it possible to switch turnouts via **loc-addresses**. For example switching with the **functional keys F1 to F4** of the **Lokmaus 2®** or **R3®**.

The **function key F1** will shift the **turnout at the output 1** and the key **F2** will shift the **turnout at the output 2** etc.

Each **stroke on a function key** will **shift the respective turnout** from round to straight or vice versa.

Also for programming the loc-addresses a turnout-drive has to be connected to the output 1 of the decoder.

- Switch on the **power supply** of your model rail way.
- Adjust the **speed** of all connected speed controller respectively Lokmauses to **zero** (center position of the adjusting dial).
- Press the **programming key S1**. Do not touch the integrated circuits of the pc-board because any electrostatic discharge can destroy the IC's.
- The turnout connected to output 1 will move now **automatically** every **1.5 seconds**. This indicates that the decoder is in the **programming mode**.

- Adjust now on one of the Lokmauses the required address and **turn the speed adjusting dial** off from the center position. If the decoder has recognized the assignment correctly the connected **turnout will move** a little **faster**. The decoder **S-DEC-4-DC** will accept **loc-addresses** between **1 and 99**.
- Adjust the **speed** now to **zero** again. The turnout will move now a little slower.
- Press the **programming key S1** again for **leaving the programming mode**.
- If you press **functional key F1** you can shift the **turnout of the output 1** with **each stroke**. If there are turnouts connected on output 2 to 4 of the decoder **S-DEC-4-DC** you can shift the respective registered turnouts with the programmed loc-addresses with each stroke of the function keys F2 to F4.

Please attend to the following:

- All 4 **decoder outputs** can switch a current of **1 Ampere** peak. Modern turnout drives need about 0.25 up to 0.5 Ampere. Older drives which are not free moving or which are dirty need more Ampere. The **S-DEC-4 Decoder** is **protected** against **overload** caused by **drives** which are not switching off at the end movement. The protector is an **automatic fuse** which will switch back into normal operation a few seconds after the load current is below maximum value.
- Turnouts with **integrated end-switch** can create considerable **electromagnetic interference**. Normally the decoder **S-DEC-4** will not be influenced by this interference. But in case the decoder will be influenced please check the **turnout installation cables**. Those cables should not wrap or cross the decoder closely. Install the cables that way that they go straight away from the clamps of the decoder. If limited space requires a bad installation layout and the

function of the decoder will be disturbed please disconnect the middle cable of each turnout connection and push about 5 to 10 ferrous pearls onto this cable before connecting to the clamp again.

- These ferrous pearls are available at electronic shops or at LDT with the order code `FP`.

Decoder application:

Besides the typical application of **turnout control** the decoder **S-DEC-4-DC** can also be used for **uncoupling tracks** and **semaphore-signals**.

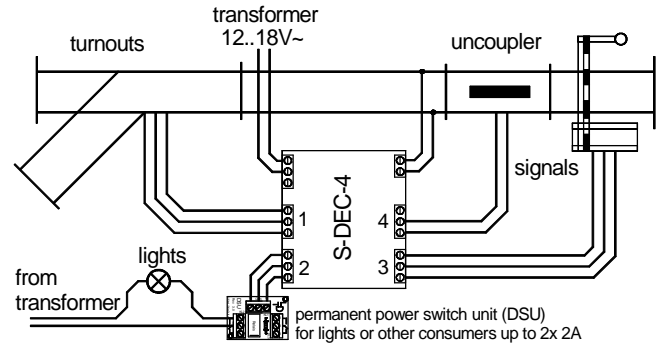

With our **permanent power switch unit [DSU]**, which is equipped with a bi-stable relay is it possible to switch lights or other consumers up to **4Amp** digital on or off.

Further application and circuit examples can be found in the **Internet** on our **Web-Site** (www.ldt-infocenter.com) at the section **downloads** and **sample connections**.

Trouble shooting:

What to do if something is not working as described above? Here some possible functional errors and possible solutions:

1. During **programming of the decoder addresses** the turnout moves within 1.5 seconds, but does not **confirm** the programming with **faster movement** by **pressing any key**.
 - **Interfered digital information at KL1** respectively considerable **lost of voltage** at the **tracks** or at the **installation!** Connect the decoder not to tracks but directly with cables to the digital control unit or to the booster instead to the tracks. Increase the cable diameter for long distances.
 - Eventually the **clamps** have been **tightened to strong** and therefore the clamps got **loose at the soldering** to the pc board. **Check the soldering connection of the clamps** at the lower side of the pc-board and re-solder them if required.
2. The turnout connected to output 1 will move always at a **faster sequence** after activating the programming key S1.
 - Start **programming** the turnout decoder S-DEC-4-DC **immediately after switching-on** the digital central unit before any loc is traveling on the track.
 - Perform a **RESET** of the digital central unit. All stored data will be preserved but the **address-repeating-memory** will be **deleted**. For **Intellibox** and **TWIN-CENTER** please switch-on the unit and press the keys **GO** and **STOP** simultaneous until the report "reset" can be read at the display.

Made in Europe by
Littfinski DatenTechnik (LDT)
 Bühler electronic GmbH
 Ulmenstraße 43
 15370 Fredersdorf / Germany
 Phone: +49 (0) 33439 / 867-0
 Internet: www.ldt-infocenter.com