

To be a Digital-Professional!

Digital driving and switching of dual-coil drives with the Roco Digital-System

The main focus of this chapter shall cover the simple installation and use of the first Turnout Decoder “S-DEC-4-DC” for dual-coil drives for switching turnouts or semaphore signals.

The first step by the construction of a digital controlled model railway layout is the installation of the digital driving. For the realization of the digital driving has the Roco digital central unit (Lokmaus or multiMAUS plus amplifier) to be connected to the power supply and to the rails.

The second step is the installation of the digital switching. The first decoder can now be connected to the supply voltage and to the digital output of the central unit.

Many of the described cable colors are typical for digital model railway layouts. Naturally is it within your option to use cable colors to your requirement. Nevertheless you should assure right at the beginning: remain to the selected cable color system and make a careful documentation for possible future fault diagnosis, for extending the system or for modification of the system.

■ General Note

CONNECTING THE CENTRAL UNIT

Connect the amplifier (10761 or 10764) to the transformer and to the Lokmaus respectively to the multiMAUS as described within the Roco installation manual.

The rail connection (digital current) will be provided by the amplifier output “Track Out” with two **black** wires on one two poles plug. As the polarity of the digital current will be important for the further installation of the layout you should use for the supply the cable identification/colors **(K) red** and **(J) brown**. To assure this you should assemble a two poles clamp near the amplifier. On this clamp you should switch over the two **black** colored wires **(black/black)** to **(K) red** and **(J) brown**. At this time is it not important which **black** wire has been connected to **red** or **brown** because the two poles plug at the amplifier can be turned around at any time if required. For both wires of the digital supply to the rails connections the following wire cross section sizes are recommended:

length of the cable	recommended cross section
up to 3 m	0.75 mm ²
up to 6 m	1.5 mm ²
up to 10 m	2.5 mm ²
more as 10 m	4.0 mm ²

For preventing power losses is it recommended to use a (first) mains ring conductor with connections to the rail system ((K)red / (J)brown) at distances of 1.5 to 2m. Each plugged rail connection will contain an electrical resistance. This resistance will be enlarged by corroded contacts etc. The resulting voltage drop at the rail connections reduces the digital voltage and it can be possible that “remote” track sections will eventually not get the full digital current – disturbances or inexplicable abnormal behavior can be expected. A sufficient diameter of the supply-wire contains a considerable lower resistance and assures therefore the full supply of the voltage to the rails.

The below picture sample shows the general connection of a central unit and the additional power supply connections at your model railway layout:

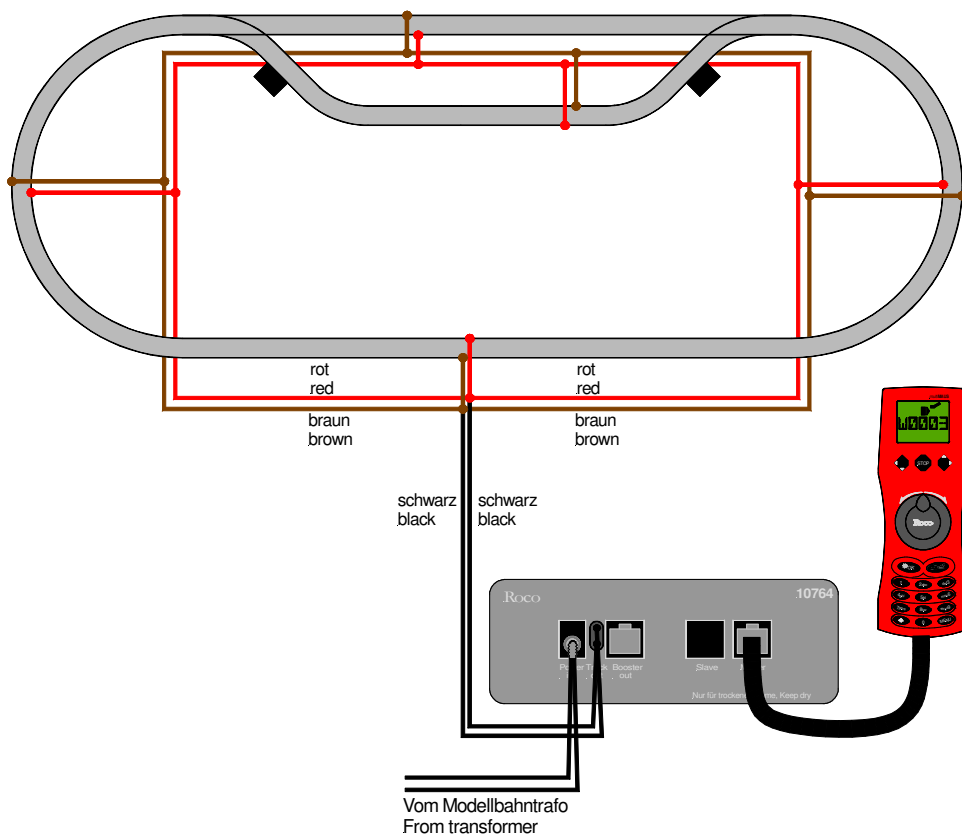

■ Connection of the Roco digital central unit (page_360)

THE FIRST TURNOUT-DECODERS (S-DEC-4-DC)

Now to the second step for the digital switching of your digital model railway layout. Also the Turnout-Decoders requires a connection to the power supply (12 – 18 V ~) and to the digital voltage. All digital commands as well as to the loc-decoders will be transmitted on this way.

The Roco Digital-System transmits data with the DCC-format for the driving of the locomotives and the switching of the turnout decoders. For the controlling of dual coil drives is therefore the application of a 4-fold turnout decoder “S-DEC-4-DC” suitable.

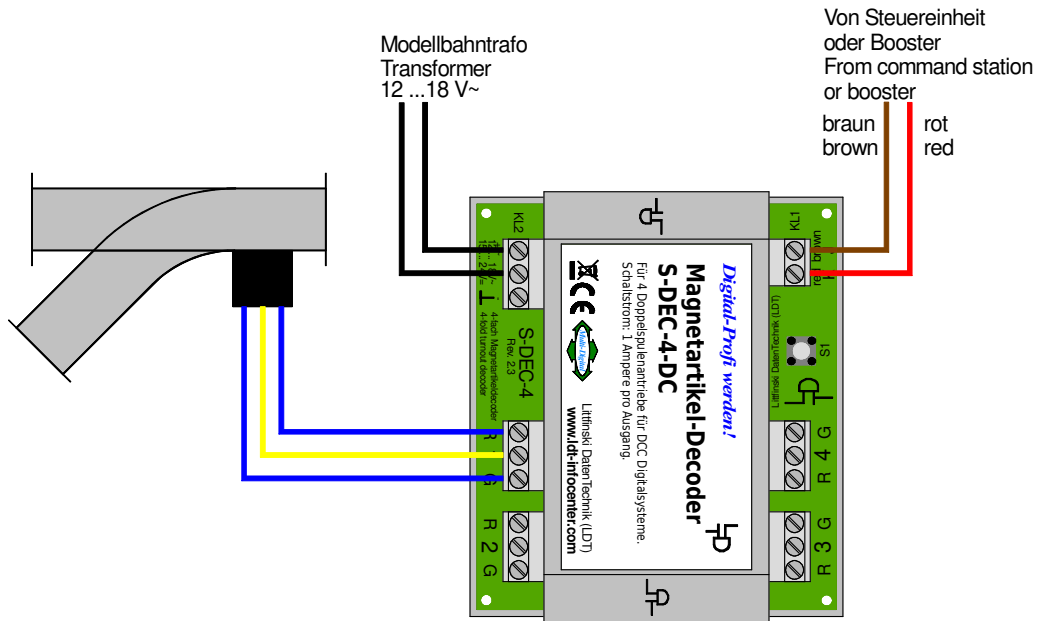

■ Connection of the Turnout-Decoder S-DEC-4-DC (page_101)

Power supply (black cables at the above sample) will be required for the module itself and the switching of the coil drives. The decoder module requires a spacing current flow of about 0.1 Ampere. Each of the four outputs can cover a maximum switching current load of up to 1 Ampere.

By connecting the supply voltage of 12 – 18 Volt ~ please pay careful attention that you use the two inputs of the clamp KL2 which are marked with “~”. One of the two terminals of the supply voltage should never be connected to the ground output “⊥” of the 3 poles clamp KL2. In this case the decoder will be destroyed as shown within the following connection sample.

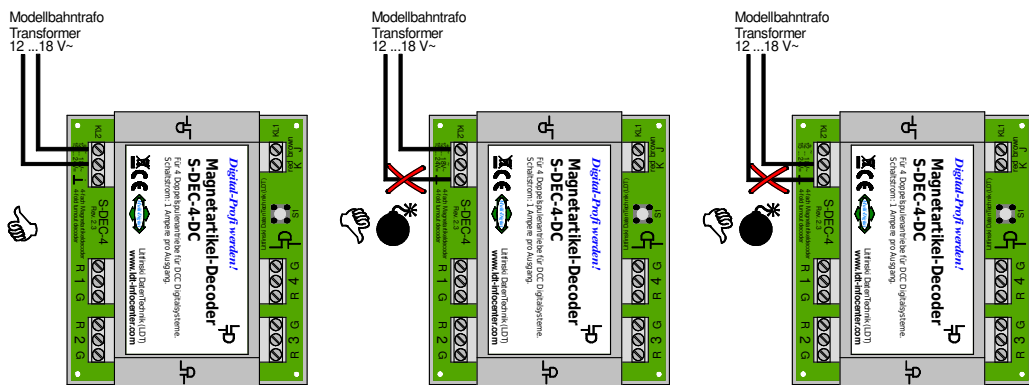

■ Correct connection of the external supply voltage (page_508)

The turnouts or signals have to be connected with three cables (**blue / yellow / blue**), which can be of a preferable short length, by a considerable close distance of the decoder to the respective turnout or signal. The common conductor of the turnout- or signal-drive (**yellow**) shall be connected to the middle contact of the decoder module marked by a digit. The clamps marked with “G” and “R” are supposed for the coil drives and are indicating the turnout position to be switched (G for straight and R for round).

General Note

If it is required to extend the connection cables of a turnout drive it has to be taken care of a sufficient diameter of the connection wires. For a maximum current of 1 Ampere at the decoder output is the ordinary used wiring of 0.14 mm² not sufficient. We recommend to use wires of 0.5 mm² for a sufficient installation.

If the available digital current supply from the amplifier 10761 or 10764 for driving and operating the layout will be insufficient is it required to use additional digital amplifiers. This requires naturally additional wiring installation and further cost (expensive digital current).

You can extend your Roco Digital Layout by up to 10 DigitalBooster “DB-2” by using the Adapter “Adap-Roco”. Each DigitalBooster “DB-2” supplies an additional current of 2.5 Ampere.

The next sample shows the connection of two from four possible turnouts and the connection of a further decoder module for additional four turnouts.

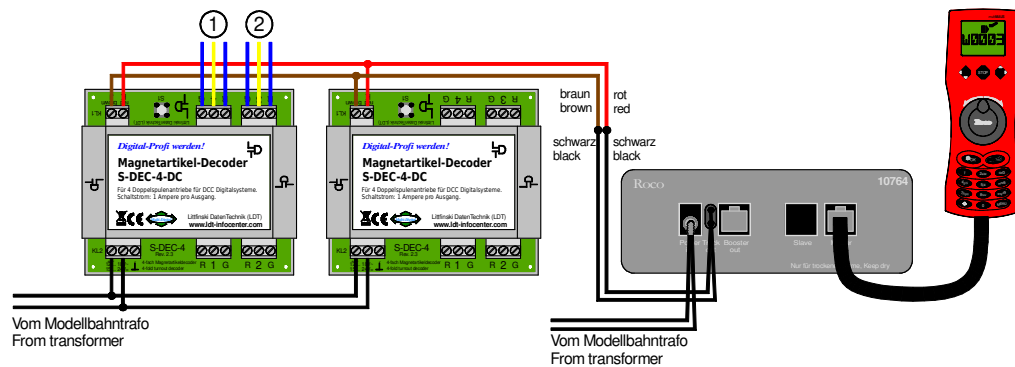
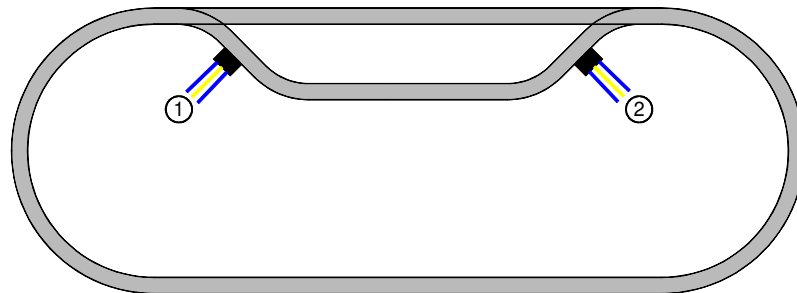

Connecting several Turnout Decoders S-DEC-4-DC (page_361)

It is recommended to install a separate second main ring conductor for the digital current to the turnout- and switch decoders ((K) **red** / (J) **brown**) and a third main ring conductor for the voltage supply (**black**).

The digital information for the accessory decoders should never be taken directly from the rails. The driving locomotives can influence the digital signal by producing continually a kind of loose contact signal. This can result to the problem that the decoder cannot understand the single signal. For this reason will be the loc commands continually repeated.

Especially for the switch commands which will not be transmitted several times as done by the loc commands is it possible that commands will be getting lost if the digital information have been taken directly from the rails.

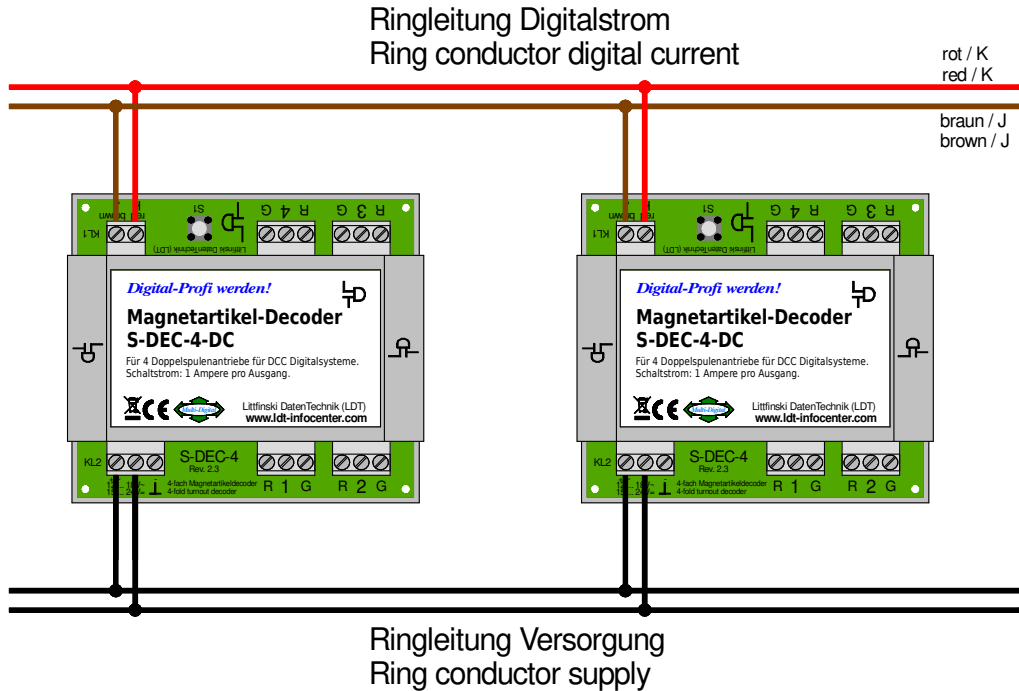

■ 2. and 3. Main Ring Conductor for accessory Decoders (page_260)

There are as well some recommendations for the wire cross-section dimension of the two main ring conductor wires. As there will be a low current flow only the wire dimension can be a little smaller.

length of the cable	recommended cross section
up to 10 m	0.75 mm ²
more as 10 m	1.0 – 1.5 mm ²

At least after completion of the wiring installation you should start a first test and the placing of a suitable digital address for the turnout (or signal).

THE FIRST PROGRAMMING

The assignment of digital addresses has to be carried out individually for each module. The address is valid for the respective complete group of four (e.g. 1 - 4, 5 - 8, 9 - 12 etc.). For setting the address (= read-in address) you have to connect a turnout to the output 1 at the module.

The turnout will start switching at a 1.5 second interval after activating the programming key at the decoder. The decoder module is now in a learning mode. Now is it required to select and activate a turnout (1 – 4, 5 – 8, etc.) at the central unit. The decoder module takes over the four addresses for the four outputs and confirms the setting by switching the connected turnout for a short period a little faster.

If the decoder does not confirm the setting by an accelerated switching of the turnout you should turn around the 2-poles plug at the amplifier output "Track Out". This will match the correct polarity of the digital current for all decoders.

Depressing again the programming key at the decoder will complete the setting of addresses. The addresses are now permanently stored at the decoder.

■ General Note

Our tip: Carry out the set-up of digital addresses before installing the decoder module below the layout because the handling of the module with all connections is much easier at a working bench. After address setting please mark the module with the assigned digital addresses (e.g. label marked with a pencil “5 – 8” for the second group of four addresses).

With this procedure the functional test has been already performed and a later malfunction after installation (e.g. defect module) can be prevented. After final installation of the unit this would be a difficult time consuming procedure.

SUPPRESSION OF INTERFERENCES

■ Technical Tip

End-off switched coil drives of turnouts can initiate interferences and therefore influencing the digital system e.g. with unreliable switching of turnouts. This problem can be solved by slipping 10 ferrite pearls onto the common connection wire (yellow) of the turnout drives. This has to be done very close to the coil housing.

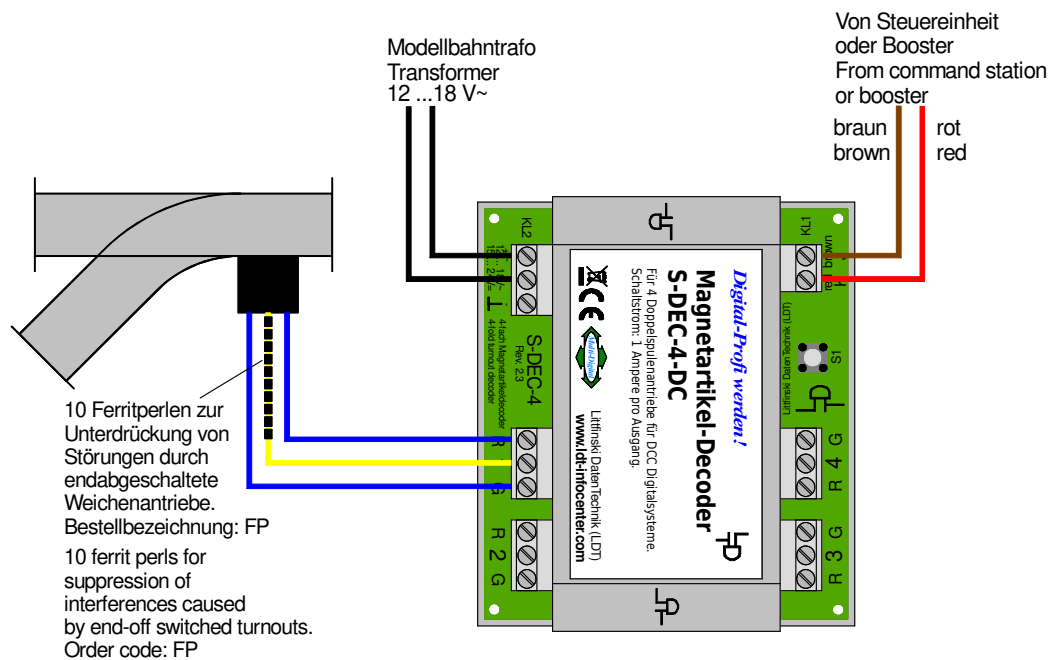

■ Ferrite Pearls for the suppression of interferences by Coil Drives (page_239)

The ferrite pearls are available by LDT under the order code “FP”. The connections and the operation of the turnouts as well as the programming the decoder will not be influenced.

SPECIAL CASE: PIKO A-RAIL DRIVES

The turnout drives of company PIKO (A-track) have to be operated with a reduced current to prevent the bouncing of the turnout latch and to assure that the current consumption will be below 1 Ampere. For the prevention is it recommended to implement at this drives at the common connection (**yellow**) a resistor with 4.7 Ω (1W). This resistor will reduce the current on both drive coils and will assure a safer operation.

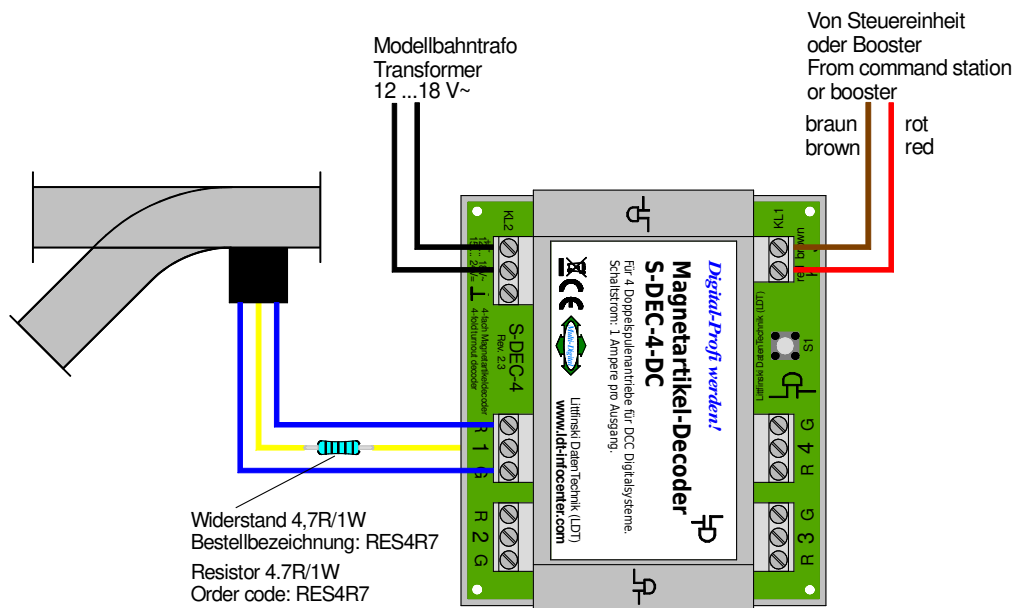

■ Serial Resistor for PIKO-Turnouts (page_256)

The resistor is available as accessory by LDT under the order code “RES4R7”. There will be no change within the connections or the operation of the turnouts as well as on the programming of the decoder.

For the suppression of interferences by those end-off switched turnouts is it recommended to apply the ferrite pearls as well on the common connection (**yellow**) of the turnouts ⇒ “Suppression of interferences” (Page 6).

FURTHER INFORMATION

Additional information about the operation of digital model railway components and further helpful connection samples are available within the operation instructions received with every purchased module and device and at our extensive Internet page. All mentioned sample connections can be loaded down as PDF files (e.g. page_360.pdf) and printed at an A4 format.

■ Internet: www.ldt-infocenter.com

Authors: Harry Kellner / Peter Littfinski

Subject to technical changes and errors.
 © 04/2022 by LDT